

# Cable-Extension Position Transducer

0...5, 0...10 VDC Output Options

Ranges: 0-2 to 0-100 inches

Instrument Grade



# PT510



## Specification Summary:

### GENERAL

Full Stroke Range Options ..... 0-2 to 0-100 inches  
 Output Signal Options..... 0...5, 0...10 VDC  
 Accuracy .....  $\pm 0.28\%$  to  $\pm 0.15\%$  full stroke *see ordering information*  
 Repeatability.....  $\pm 0.05\%$  full stroke  
 Resolution ..... essentially infinite  
 Measuring Cable ..... *see ordering information*  
 Enclosure Material..... powder-painted and anodized aluminum  
 Sensor ..... plastic-hybrid precision potentiometer  
 Potentiometer Cycle Life ..... *see ordering information*  
 Maximum Retraction Acceleration..... *see ordering information*  
 Weight..... 2 lbs. max.

### ELECTRICAL

Input ..... *see ordering information*  
 Input Current..... 10 mA maximum  
 Output Impedance..... 1000 ohms  
 Maximum Load ..... 5000 ohms  
 Zero Adjustment ..... from factory set zero to 50% of full stroke range  
 Span Adjustment..... to 50% of factory set span

### ENVIRONMENTAL

Enclosure ..... NEMA 1  
 Operating Temperature ..... -40° to 200°F (-40° to 90°C)  
 Vibration..... up to 10 G's to 2000 Hz maximum

Based on Celesco's original string pot design dating back to the late 1960's, the PT510 has become a standard throughout the years for literally thousands of applications including aircraft structural testing, hydraulic cylinder control, valve stem opening, and factory automation.

Available in full stroke ranges up to 100-inches, the PT510 provides a regulated voltage feedback signal linearly proportional to the position of its traveling stainless steel measuring cable. Output signal options include 0-5 and 0-10 vdc.

fig. 1: Top Exit Option

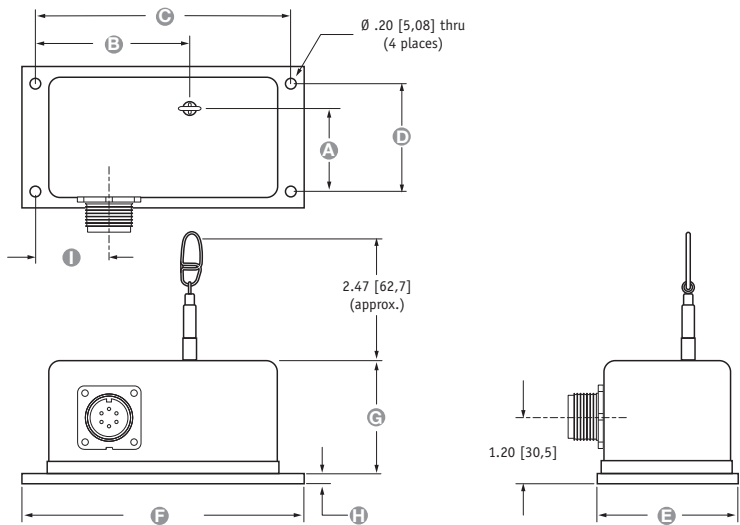

Range	A	B	C	D	E	F	G	H	I
2", 10", 20"	1.34 [34,0]	4.00 [101,6]	7.00 [177,8]	2.00 [50,8]	2.63 [66,8]	7.50 [190,5]	2.10 [53,3]	.16 [4,1]	1.37 [34,8]
5", 25", 50"	1.83 [46,5]	4.00 [101,6]	7.00 [177,8]	2.00 [50,8]	2.63 [66,8]	7.50 [190,5]	2.10 [53,3]	.16 [4,1]	1.37 [34,8]
15", 30"	1.56 [39,6]	4.00 [101,6]	7.00 [177,8]	2.00 [50,8]	2.63 [66,8]	7.50 [190,5]	2.10 [53,3]	.16 [4,1]	1.37 [34,8]
40"	1.64 [41,6]	4.00 [101,6]	7.00 [177,8]	2.00 [50,8]	2.63 [66,8]	7.50 [190,5]	2.10 [53,3]	.16 [4,1]	1.37 [34,8]
60"	2.16 [54,9]	4.19 [106,4]	7.00 [177,8]	2.37 [60,2]	3.25 [82,5]	7.50 [190,5]	2.60 [66,0]	.19 [4,8]	1.37 [34,8]
75", 80"	2.45 [62,2]	4.38 [111,3]	6.75 [171,4]	2.50 [63,5]	3.63 [92,2]	7.50 [190,5]	2.86 [72,6]	.19 [4,8]	1.37 [34,8]
100"	3.10 [78,7]	4.19 [106,4]	7.38 [187,5]	3.00 [76,2]	4.25 [108,0]	8.00 [203,2]	3.79 [96,3]	.19 [4,8]	3.69 [93,7]

ALL DIMENSIONS ARE IN INCHES [MM] tolerances are  $\pm 0.02$  in. [ $\pm 0.5$ mm] unless otherwise noted

## Electrical Output Signal

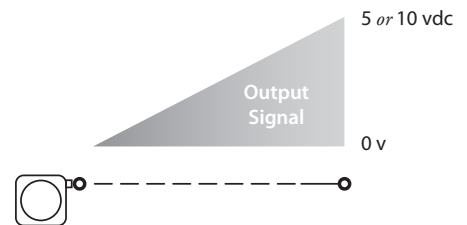

**Ordering Information:**

**Model Number:**

PT510 - 1 - 1 - 0  
order code:      R      A      B      C      D      E      F      G

Sample Model Number:

PT510 - 0025 - 111 - 1110

- R** range: 25 inches
- A** measuring cable tension: standard - 5 oz.
- C** cable exit: top
- E** output signal: 0...10 VDC
- F** electrical connection: 6-pin plastic connector

**Full Stroke Range:**

<b>R</b> order code:	0002	0005	0010	0015	0020	0025	0030	0040	0050	0060	0075	0100
full stroke range, min:	2 in.	5 in.	10 in.	15 in.	20 in.	25 in.	30 in.	40 in.	50 in.	60 in.	75 in.	100 in.
accuracy (% of f.s.):	0.28%	0.28%	0.18%	0.18%	0.15%	0.18%	0.15%	0.15%	0.15%	0.15%	0.15%	0.15%
potentiometer cycle life*:	2.5 x 10 <sup>6</sup>	2.5 x 10 <sup>6</sup>	5 x 10 <sup>5</sup>	5 x 10 <sup>5</sup>	5 x 10 <sup>5</sup>	5 x 10 <sup>5</sup>	5 x 10 <sup>5</sup>	2.5 x 10 <sup>5</sup>	2.5 x 10 <sup>5</sup>	2.5 x 10 <sup>5</sup>	2.5 x 10 <sup>5</sup>	2.5 x 10 <sup>5</sup>

\*-1 cycle is defined as the travel of the measuring cable from full retraction to full extension and back to full retraction

**Measuring Cable Tension:**

<b>A</b> order code:	1		H		2*		3*	
	standard tension		high tension		*note – outline dimensions for these options are not controlled on this datasheet!			
	tension, ±20%	max acceleration	tension, ±40%	max acceleration				
2, 10, 20 inch range:	12 oz.	• 11 g	65 oz.	• 53 g	72 oz.	144 oz.		
5, 25, 50 inch range:	5 oz.	• 2 g	26 oz.	• 11 g	30 oz.	60 oz.		
15, 30 inch range:	8 oz.	• 3 g	43 oz.	• 23 g	48 oz.	96 oz.		
40 inch range:	6 oz.	• 4 g	33 oz.	• 16 g	36 oz.	72 oz.		
60 inch range:	13 oz.	• 4 g	22 oz.	• 8 g	26 oz.	52 oz.		
75, 80 inch range:	10 oz.	• 3 g	40 oz.	• 12 g	20 oz.	40 oz.		
100 inch range:	13 oz.	• 5 g	52 oz.	• 20 g	26 oz.	52 oz.		
measuring cable:	.019-in. dia. nylon-coated stainless steel				.024-in. dia. stainless steel			

**Measuring Cable Exit:**

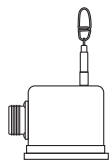
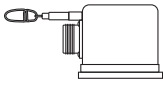
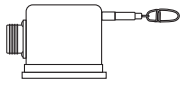
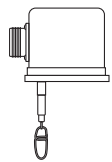

<b>C</b> order code:	1	2	3	4
	top exit (see fig. 1)	front exit*	rear exit*	bottom exit*
				

\*-note: dimensions for optional cable exits not controlled on this datasheet, please contact factory

**Sensing Circuit:**

<b>F</b> order code:	1	2	3	4
output signal options:	0...10 VDC	0...5 VDC	10...0 VDC	5...0 VDC
input voltage:	14.5 - 40 vdc	10.5 - 40 vdc	14.5 - 40 vdc	10.5 - 40 vdc





Example:

ordercode = 1 = 0...10 vdc {  = 0 vdc     = 10 vdc

**Ordering Information (cont.):**

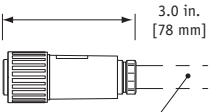
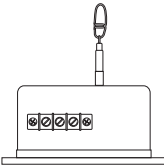
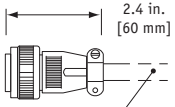

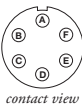

**Electrical Connection:**

**F** order code:

1	2	3	4																							
6-pin plastic connector with mating plug	terminal strip	6-pin metal connector with mating plug	25-ft. instrumentation cable 24 AWG, shielded																							
																										
1/2 - 5/16" [14 - 8 mm] cable dia. 16 AWG max conductor size connector: MS3102E-14S-6P mating plug: MS3106E-14S-6S		3/8-in. [9 mm] max cable dia. 16 AWG max conductor size connector: MS3102E-14S-6P mating plug: MS3106E-14S-6S	25 ft. x 0.2-in. dia. [7,5 M x 5 mm dia.] 24 AWG, shielded																							
<p><b>6-pin mating plug:</b></p> <table border="1"> <thead> <tr> <th>pin</th> <th>signals</th> </tr> </thead> <tbody> <tr> <td>A</td> <td>input voltage</td> </tr> <tr> <td>B</td> <td>output signal</td> </tr> <tr> <td>C</td> <td>common</td> </tr> </tbody> </table>  <p><i>contact view</i></p>	pin	signals	A	input voltage	B	output signal	C	common	<p><b>Terminal Strip:</b></p> <table border="1"> <thead> <tr> <th>terminal</th> <th>signals</th> </tr> </thead> <tbody> <tr> <td>1</td> <td>input voltage</td> </tr> <tr> <td>2</td> <td>output signal</td> </tr> <tr> <td>3</td> <td>common</td> </tr> </tbody> </table> 	terminal	signals	1	input voltage	2	output signal	3	common	<p><b>25-ft. instrumentation cable:</b></p> <table border="1"> <thead> <tr> <th>color code</th> <th>signals</th> </tr> </thead> <tbody> <tr> <td>RED</td> <td>input voltage</td> </tr> <tr> <td>BLACK</td> <td>common</td> </tr> <tr> <td>GREEN</td> <td>output signal</td> </tr> </tbody> </table>	color code	signals	RED	input voltage	BLACK	common	GREEN	output signal
pin	signals																									
A	input voltage																									
B	output signal																									
C	common																									
terminal	signals																									
1	input voltage																									
2	output signal																									
3	common																									
color code	signals																									
RED	input voltage																									
BLACK	common																									
GREEN	output signal																									

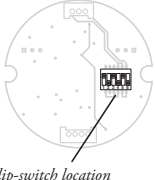
**Output Signal Selection:**

The output signal direction can be reversed at any time by simply changing the dip-switch settings found on the internal signal board. After the settings have been changed, adjustment of the Zero and Span trimpots will be required to precisely match signal values to the beginning and end points of the stroke.

output signal	switch setting	signal board
0...10 vdc		
10...0 vdc		
0...5 vdc		
5...0 vdc		

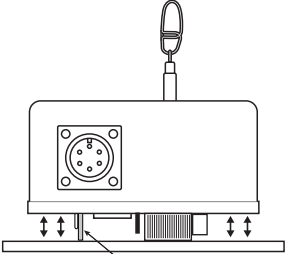

*internal dip switches & signal board*

To gain access to the signal board, remove the two 4-40 screws on top and lift up cover.

version: 5.0 last updated: May 24, 2011